



Advanced CCS/CCU Laboratory Solutions by fluidXlab

Take Action Against Climate Change

At fluidXlab, we understand the importance of climate change and provide accurate, fast and reliable laboratory solutions designed to help our clients optimise their CCS/CCU processes and thus contribute to decarbonisation.

Comprehensive & Specialised Measurements for Maximum Impact

Our focus on efficiency, accuracy, and automation makes us the preferred partner for technical experts in CCS/CCU, PVT, and departments active in core flooding and simulation. In addition, our newly upgraded PVT lab allows us to offer a specialised set of measurements for CCS/CCU, combined with advanced microfluidics technology.

fluidXlab's Contributions to CCS & CCU Processes Optimising Underground Storage & EOR/IOR for a Greener Future

By providing valuable laboratory data in a timely manner, we assist clients in optimising underground storage operations and evaluating the geological and technical integrity of underground carbon dioxide storage projects.

We also provide laboratory data that helps clients optimise enhanced/improved oil recovery (EOR/IOR) processes with carbon dioxide, such as miscible gas injection or carbonated water flooding.

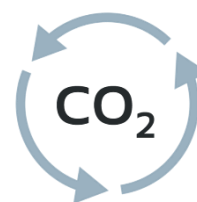

fluidXlab's Specialised Services for CCS/CCU Processes PVT, Microfluidics Technology and More

In addition to our conventional lab services covering PVT & Phase Behaviour, Fluid Analysis, Rock-Fluid Compatibility, Porous Media Flow & Caprock Integrity and Diffusion, we are a leading provider of comprehensive laboratory services for investigating CCS/CCU applications:

PVT, Phase Behaviour & Transport Properties of CO₂ Mixtures

We characterise CO₂ mixtures at HPHT and sub-ambient conditions:

- ▮ Dew point
- ▮ Content of water and alcohol in gas at ppm levels
- ▮ Composition and volumes of liquid dropout
- ▮ Single phase and VLE density and viscosity

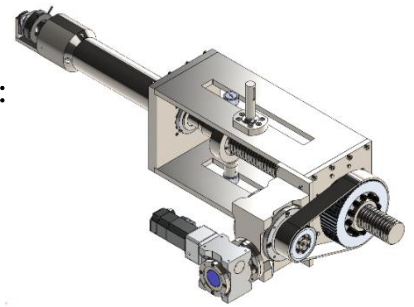

Microfluidics

To complement the above, we also offer **advanced microfluidics technology** for fast and accurate **carbon dioxide testing at high pressure and extreme temperature conditions**, requiring only a few millilitres of sample:

- ▮ **Minimum miscibility pressure (MMP)**
Oil volume required per experiment: 2 ml
Experiment duration: 3 h
- ▮ **Asphaltene and wax precipitation**
Oil volume required per experiment: 1.5 ml
Experiment duration: 3–6 h
- ▮ **Drying of CO₂ wells and salt precipitation**
- ▮ **Recovery factors and oil displacement mechanisms on porous micromodels**
Oil volume required per experiment: 3 ml
Experiment duration: 8 h

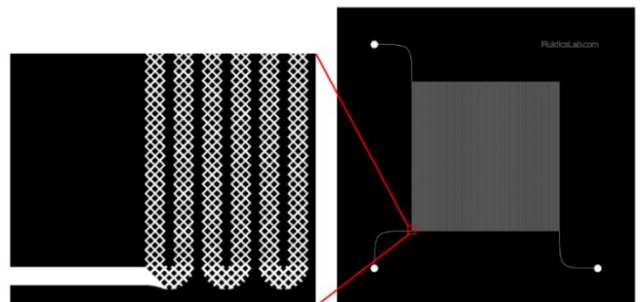

Fluid testing micromodel for MMP and flow assurance

Let's streamline your lab!

Visit: www.fluidXlab.com

Contact us at fluidXlab@hoteng.com

About us

HOT fluidXlab's activities focus on experiments with hydrogen (H₂), carbon dioxide (CO₂) and oil & gas mixtures in compliance with the highest HSE standards. The company helps energy companies and research organisations around the globe perform lab experiments faster and at significantly lower costs. The turnkey InspiOR® device is the industry-leading microfluidic flooding platform and is a registered trademark of the HOT Energy Group.

